



THE BILGE PUMP

The Official Log of the
Northwest R/C Ship Modelers

September 2008



Upcoming Events

September

- 1 Skagit R/C Ship Modelers
7:00 pm PUD, Mt. Vernon
- 4 NWRCSM Meeting
7:00 pm, Galaxy Hobby
- 7 Fun Float/Springer Event
12:00 pm, Bellevue Pond
- 20 Fall Fisherman's Festival

October

- 2 NWRCSM Meeting
7:00 pm, Galaxy Hobby
- 5 Fun Float
12:00 pm, Bellevue Park
- 6 Skagit R/C Ship Modelers
7:00 pm PUD, Mt. Vernon

November

- 3 Skagit R/C Ship Modelers
7:00 pm PUD, Mt. Vernon
- 6 NWRCSM Meeting
7:00 pm, Galaxy Hobby
- 9 Fun Float
12:00 pm, CWB Lake Union
- 13-15 Pacific Marine Expo
Quest Field



Red Right Returning

By Randy Flodquist

Autumn arrives this month, my favorite season (when the air gets crisp and the trees turn colorful) when the school year arrives fresh and bright.

The model boating season is winding down but has it been a dandy Summer! Over twenty of us had an excellent time in Tualatin where the weather was cooler by ten degrees than usual which had us all tired out because we didn't take breaks or siestas. It was great to have Gordy and Linda back by the pond. Next year we could make thirty! Nine wives made for a nice social time among friends. It occurs to this writer that we are also the NWRCSM and Social Club; an excellent idea as ya only got so much time.

And yesterday we had the FOSS CUP (guess you know when I'm writing this) and was it ever successful!!! Get this, we had spectators who came with comfy chairs, coolers, and stayed all day in the shade on the south shore of the pond in Downtown Park, Bellevue. We had Mr. Ray Malone all the way from England with his beautiful tug GALE WIND and he even took home some hardware. Nice to meet you Ray, please do come back again.

Linda (with the help of Ruthie and Ginny) provided a delightful breakfast and Linda Canney jumped in and helped with lunch. We ate well and drank up all the water and almost all the pop as it was a 90 degree day. The wind saved us (even though not all the tug drivers would agree) and Leif took us for over \$800 in raffle tickets which guarantees us another Foss Cup in 2009.

Best of all, Keith Schermerhorn won the coveted cup with his vintage tug LIBERTY! Way to go Keith; your days of being a bridesmaid are over. It was a good day and with a few more than usual helping, we made it out into the 520 traffic at six-thirty in the evening. Those with energy left over the next morning went across the 49th parallel and attended the Burnaby event which was also successful. Lee Duval did Tualatin, Foss Cup, and since he was here he continued on to Canada, all from his home in San Francisco.

CLUB OFFICERS

President

Randy Flodquist
flodquist1@comcast.net

Vice Pres.

Allan Wing
allanwing@clearwire.net

Sec / Treasurer

Ed Maurer,
marthaed606@verizon.net

Webmaster/ Newsletter Distribution

Gordon Canney
wb7okg@gte.net

Newsletter Editor

Darlene Wing
darlenewing@clearwire.net



Skagit R/C Meeting Contact

Keith Schermerhorn
wscherm@fidalgo.net



Red Right Returning continued

We can go play in Spreckle's Lake in Golden Gate Park with Lee on October 11 for the 2008 Wooden Boats on Parade. What a nice time of year to drive down 101 and then California 1 and across the Golden Gate Bridge to that wonderful city by the bay. If ya can't afford the gas or time we've got the twentieth FALL FISHERMAN'S FESTIVAL at the terminal on the twentieth of September. It's another good day with good water, maritime booths, live music, USCG demonstrations, salmon dinners provided at reasonable cost by Anthony's and the rain has held off until we pack up. Swell.

Of course, backing up a little, the tug races in Olympia the day before Labor Day are always worth a gander. Talk you way onto a boat; it's exciting. Over the same weekend is the Classic Boat Festival in Victoria in the inner harbor. We'll be in Victoria the following week (but will still have time to play in Harrison Pond) and will miss the meeting and float. Allan will also miss the meeting at Galaxy. So be there at seven and listen to Mr. Ed.

Wiring By Allan Wing

Last month I talked about loose grounds. This month I will show how to provide a separate power source to high powered servos. In a recent meeting Mel had talked about a member that had problems with his Spektrum receiver losing sync because the servo drew so much current it lowered the receiver battery voltage. To add a separate power supply, you just cut the positive (red) wire between the servo and receiver and connect this red wire from the servo to the positive lead of the battery. Then connect the negative (black) wire from the battery to the black wire still connected from the servo to the receiver. The before and after is pictured below.

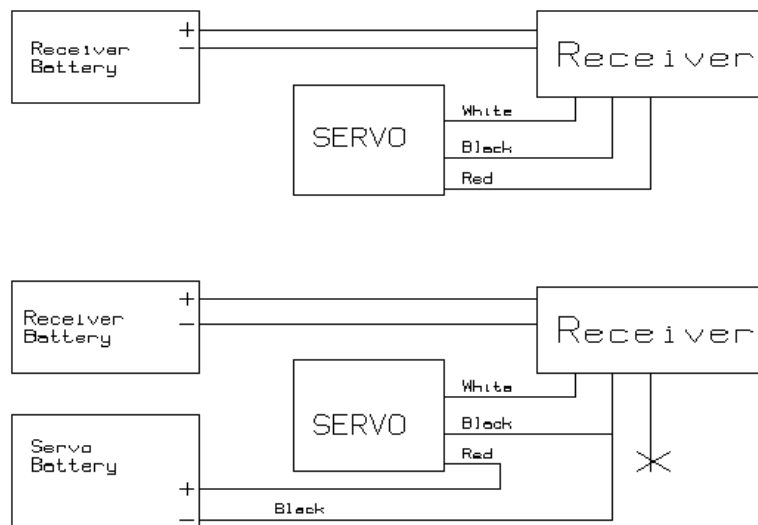

Northwest R/C Ship Modelers Meeting Minutes

By Allan Wing

The meeting was called to order at 1910 in an attempt to start at the new slightly earlier time. We only had 18 members with Phil on the disabled list with a bad back and a few members already on their way to Tualatin. Capt. Dick Weightman donated a couple of boats and some equipment to the club. Randy suggested that the radio and battery charger be donated to the Foss Cub for raffle prizes.

Ben talked about the Tidewater Cup at Spokane. He noted it was a cool day for Spokane but good conditions. The course had been changed so that the boats did not go around the fountain. Our club won some 8 of the 11 ribbons awarded with Ben winning the overall award.

Randy then presented plaques to Mat and Pat Plueard for their winning efforts in the June Regatta.

Randy talked about the event at Tualatin. It looks like we will have about 20 members at the event and other festivities.

Tom talked about the Foss Cup. He passed around a copy of a map of the course. He said the salvage runs would be scheduled such that each boat would do the salvage run immediately after the barge run. This is hoped to make the running of the event quicker. He made a request for chairs and Ice chests with ice.

I started the show and tell with a demonstration of the article I wrote in last months news letter. I had wiring simulating two speed controls connected to a receiver, I removed the ground to one speed control and showed the result of the ground current flowing through the small wires going to the receiver. The small wire got hot turned red and melted the insulation with a bit of smoke.

Barry showed his Lindbergh model of a Fletcher Class destroyer. He plans to make some modifications to the running hardware to make it full radio control with the gun turrets tracking the steering.

Next Dave Feray showed his Liquefied Petroleum Barge. He has made it with a pump so he can fill and empty the large gas cylinders to simulate loaded and unloaded conditions.

Randy showed his French Tug, the Lug, that he had made some years ago while teaching classes at the Center for Wooden Boats. He had tried to convert it to R/C but found it had very little displacement so it tended to ride too low in the water.

Finally, Tom showed the hook he had made to use for Salvage at the Foss Cup. With that we stacked the chairs at 2020.



Skagit R/C Ship Modelers Meeting Minutes

By Keith Schermerhorn

It was a warm and comfy Monday evening when the small group of 12 met to discuss model boating adventures. Of the items discussed, the fun float that was hosted by Gordon at the park pond where he lives was a great success. Several people came out to watch the half dozen boats parade around the pond showing the fun of the hobby to the residents. Thanks Gordon for a fun afternoon as we will try and do this again. Keith gave a report on the wedding ring delivery he did with a barge and one of his tugs. The outcome was very well received with surprise to all the visitors at the wedding. A lot of time was discussed on the things one should do before crossing the border to go to an event, such as Burnaby, to ease the crossing. Best if one has a complete inventory of their projects that are coming back with them. Other topics of discussion included all the upcoming events in August and the fall before the building season begins. Larry invited anyone that would like to watch or participate in the Monday evening sail boat races held in Anacortes by the seafarer's monument to come out. We also got an update on Vic's health. He is feeling better although they are still not sure what has been ailing him. Get well soon

After a short break, we were given a presentation by Mr. Gordon Johnson on the building fishing trawler he has been working on. Gordon was Canadian born but now a US citizen along with his wife. He decided to build the current model from one that a friend had partially completed. After much consideration, he decided to build one twice the size as he felt the original was too small. Some of the interesting items on this model are the keel that was made from an old weaver's loom and the double planked electrical tape to simulate the caulking on the deck. It took 1 year to finish the model as is. He worked from drawings and photos of the prototype. After the presentation we all headed back to our home ports at about 2000 hour. It was a short, but informative gathering that will be longer in September as there will be several items to discuss from August.

August Fun Float

By Allan Wing

We had a typical warm and sunny August Searfair day for our fun float. We had a good turnout. Mark Gordon showed up with his two aircraft carriers. These are very nice boats and it was nice to have him visit. The Blue Angles flew over the pond a couple of times to add some excitement. I tried to measure the speed of a few boats with a small wrist GPS. It seemed to have a little trouble with the signal when close to the water but I got some measurements. My sail boat topped out at 2.2 mph, the Henry Foss went 3.5 mph and Mel's PT boat sent 5.4 mph. I expect that the PT boat really went faster but we need to find a better way to really measure speed.



Check out the web edition of the newsletter for additional pictures.

TUALATIN 2008

By Dr. Ron

The NWRC group arrived at the Tualatin Commons on Thursday and Friday for the float and competition on the 9th. Those who were fortunate to make the trip and survive the gas and hotel bills were the Suelzle's, Canny's, Flodquist's, Feray's, Bauman's, Bray's, Bentzen's, Chinn's, Lingsheids, Kinsman, McGee, Ed Mauer and the Forlines from Shelton. Twenty of us met for dinner at Hayden's on Friday night for a great dinner and get together.

The event was sponsored by the Portland Model Boat Association and the Queen's Own Combat Warships Club which provided PA announcements, music, a great lunch and raffles, not to mention a great array of exquisite models. After the raffle, a navigation event took place which proved to be quite a challenge.

Others attending the event were the San Francisco Model Yacht Club, represented by Ken Valk and Lee DuVall, the submarine group from Vancouver, B.C. and Bellingham and the Boise contingent with Mike Hoyne.

Some of the outstanding models were two 11 foot aircraft carriers, several Missouris (Iowa Class), the battleships Bismark and Oregon, a large pleasure cruiser, a San Francisco fishing trawler, small steam launches a Coast Guard boat, Springers, tugs, RTR's and of course some great models from our club members. After a collision between Al's and Scott's boats, Ben rescued the top of Scott's boat which was about to sink by conscripting Ami's leaky rubber raft. One of the small steam launches sunk and was rescued by one of the Portland club members who had to dive down in the murky water to retrieve it. Following dinner, a number of members participated in the lighted night float.

The event was fun filled not only from the standpoint of the fun float and competition but also by the Crawdad Festival with live music on Friday night along with a crawdad cook off, a marathon race Saturday morning followed by a pancake breakfast, a parade, the festival itself in the park and topped off with a movie on the lawn with popcorn.

A great hurrah and kudos go to the hosts for providing an outstanding venue and to the Tualatin Commons for such great facilities. Other than a bit of rain on Friday night the weather was great. This is an event to definitely be put on the docket for next year.



Pictures by Ron Bray

Foss Cup

By Tom Stevens

Fellow Boaters,

I have survived another year of Foss Cup. I have stepped-down from the Directors position to “get a life”. This year, “behind the scenes”, was intense. We now have responsible people in various positions. Huge thanks to Ron Bray for “stepping-up” to the position of Treasurer for Foss Cup. Also, thanks to Mike Moor, (who initiated Foss Cup, some time ago, “handed the baton” to Keith Schermerhorn, due to a very busy work and home life) who has returned to be on the Foss Cup Board of Directors. Mike has been Salvage Judge for two years, now. He is looking forward to “fine-tuning” that portion of the event. He will also be able to have valuable input to the Board, as he knew what the “long-term” goals of the organization were to be, from the beginning

This year, I believe the Event was a success – only due to the numerous people that were willing to put-in some “sweat and tears.” Allan Wing made a beautiful Poster, which we had posted in various hobby stores and other businesses. Keith made directions for the Navigation Course, registration paperwork, purchased trophies, loaded, transported and unloaded the tables, plus too many items to list. Al Kinsman and Ben Flodquist came to my place to load the big items in my trailer and John Pineau and Alan Burchett unloaded them and helped store them away, after the event. Al Kinsman also picked-up the Raffle Items from Western Towboat, who has been a strong supporter of the Foss Cup for several years. Al also made several trips to LaConner to transport the Pass. Randy Flodquist, who worked for days before the event and after - to bring the list of items that we requested from him and a lot of food transporting. I am glad that he and Ben are the ones that load and unload that huge BBQ! Linda Flodquist did another fantastic job of purchasing food and she and her wonderful crew toiled in the heat to prepare, cook and serve the food, at the event. As usual – it was EXCELLENT! Ben worked the Salvage Course with Barry Bertran, to retrieve the freighter, after each were towed to the dock. Gary King video-taped the event -all day. Ron Burchett brought down some diorama for the Navigation Course, tie-up lines and his fool-proof salvage hook. Ron tied-up barges all day. He and Dave white shared Pond Master responsibilities. Ed Maurer spent the entire day, entering scores in the computer. Mel brought the floats to divide the courses from the free-run area and also brought his wonderful gravel barge. Kevin Klocke brought several barges for the event. Wayne Martin has photographed the event for more years then I can remember, but this year he had a family event to attend, so Steve Anderson volunteered to do the job. Ron Bray is composing a couple of articles for a couple of R/C magazines. Leif Bentzen sold more raffle tickets then ever had been sold before. The Navigation Course judges were the same as in years past. Jim Martin and Andy Anderson are always a pleasure to have judge. They add humor, excellent advise and numerous years of experience of skippering the full-sized tugs to back-up their judgments.



As for the event, it went pretty smoothly. There were 29 boats that competed. They came from our local area, Oregon, Eastern Washington, British Columbia, California and Ray Malone came all the way from London, England to compete. Ray even brought his own tug! We had two very young skippers this year that did a great job. One was Darcy Pineau of Nanaimo, BC and the other young skipper was Jason Anderson of Mount Vernon, Washington.

Although there were tugs with twin-screws, Z-drives, Quartz nozzle drives, bow thrusters, towline releases, the one who did the best job and won the event was **Keith Schermerhorn** of Bellingham, Washington. He did the job with a single-screw, old-fashioned tug! I guess that shows that skill is the most important factor!

Again thanks to those that I have worked with, throughout the years on Foss Cup and all of you that when I asked, offered to help, this year! We can only hope that it will be several degrees cooler – next year!

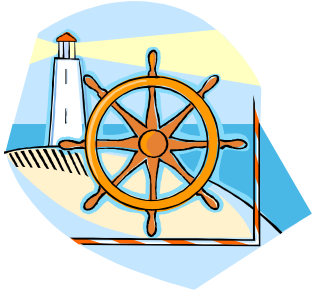

Member Spotlight

By Dr. Ron

EARL ANDERSON

Earl Anderson was born at Swedish Hospital in Seattle. He spent his early years in Ballard, but moved to Laurelhurst and graduated from Roosevelt High School. He graduated from the University of Washington with a degree in civil engineering. Following his degree, he spent two years in the US Army stationed at Fort Ord in the adjutant corps. After fulfilling his military obligation, he worked with his father in the family owned Anderson Bridge Company. In 1968 he formed his own company, E.R. Anderson Co., General Contractor.



Earl's nautical background started when he was 13, racing Geary Flatties from the Laurelhurst Beach Club. He taught sailing at Seattle Yacht Club and was a competitive racer with his Cal 40 sailboat, Madrugador, which he purchased in 1973. In 1990 he bought a Grand Banks 42 Classic, a natural transition for most stick boaters. In 1998 he upgraded to a Grand Banks 49 Classic, which he moors in Edmonds.



Earl first became interested in RC model boats when he witnessed one of our tug events at the Bellevue pond while strolling around the park. His first model was the Model Shipway Azia, followed by three Springers, one of which is a super Springer with twin screws. He designed and built a Dolphin class tug with only the help of pictures and constructed a mold so others could build their own Dolphin models. Between boats he managed to produce some super cool buoys and a lighthouse for the regatta and Foss Cup events. Also, adorning the event landscape is a fully operational floating crane barge with all kinds of novel construction parameters.

Earl and his wife, Jan, have lived in Bellevue for 43 years where they raised their two daughters. They host an annual Springer Polo event at Killarney Circle Pool which enables members to practice their crash and bash skills. We look forward to learning new modeling techniques from Earl, such as how to cool motors with radial fins and how not to bum up speed controllers by the appropriate use of fuses. His builds with styrene have set the mark for us to follow.



Meeting August 7, 2008



Fun Float August 3, 2008



Tualatin August 9, 2008

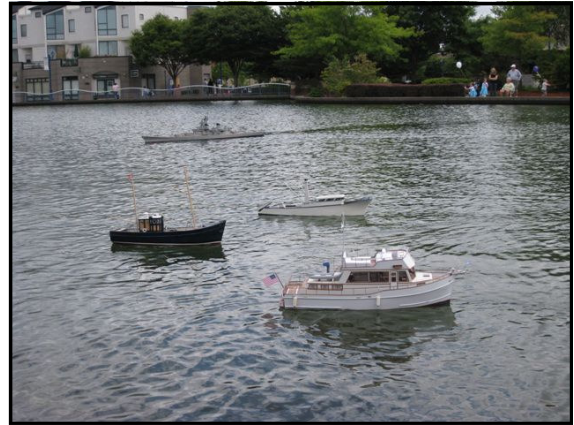

Foss Cup August 16, 2008

